

Chapter 10

Constructions and Loci

NOTE ON HOMEWORK!

- For **ALL** homework problems in this chapter that require a **CONSTRUCTION**, you **MUST**:
 - **LIST, IN ORDER, ALL STEPS** required to do the construction
 - **PERFORM** the actual construction
- This will **REQUIRE** the use of:
 - **A RULER**
 - **A COMPASS**

Objectives

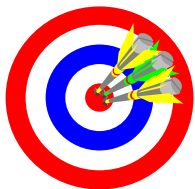

- Use the terms defined in the chapter correctly.
- Properly use and interpret the symbols for the terms and concepts in this chapter.
- Appropriately apply the theorems in this chapter.
- Understand and apply basic constructions.
- Correctly identify and describe two dimensional loci.
- Correctly identify and describe three dimensional loci.

Section 10-1

What Construction Means
Homework Pages 378-379:
2-24 evens
Excluding 10, 14, 20
Remember to list all construction steps in
order and perform the construction.

Objectives

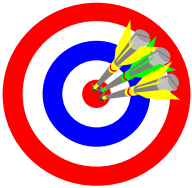

- A. Understand and apply the term 'construction'.
- B. Understand and apply the construction of congruent line segments.
- C. Understand and apply the construction of congruent angles.

D. Understand and apply the construction of an angle bisector.

Understanding Constructions

- A 'construction' is the act of building a figure based on geometric principles.
- Constructions are based on:
 - What we know about lengths of lines
 - What we know about a circle, its radius, and the relationship between its radius and circumference
 - What we know about angles
- You will need to use this knowledge to construct proper figures.

Construction 1

Given: a segment \overline{AB}

Construct: a congruent segment

Steps for construction:

Draw a line (*clearly longer than the given segment*)

Choose any point (C) on the line (*choose wisely!*)

Set the compass radius to the length of the segment AB that you want to copy

Using the point (C) that you chose on the line as a center, make an arc intersecting the line at a new point (D).

Segment CD is congruent to the segment AB.

When practicing this construction, check your result with a ruler.

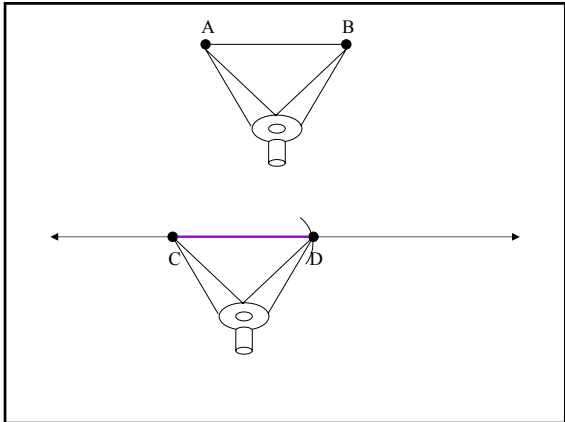

Justification for Construction 1

Think of constructions as 'applied proofs'.

Using geometric definitions, postulates, theorems, and corollaries, how can we justify (prove) that our construction is valid?

What is the definition of a circle?

All coplanar points equidistant from a single fixed point.

What is the definition of a radius?

The line segment from the center of a circle to any point on its circumference.

What is the definition of congruent circles?

Circles with the same radii.

In this construction, we have basically drawn portions of two circles with equal radii.

Therefore, congruent circles leads to congruent radii which leads to congruent line segments.

Construction 2

Given: $\angle A$

Construct: A congruent angle

Steps for construction

Draw a ray BC

Set the compass to any radius and draw an arc that intersect both sides of the angle (A) at points D & E

Using B as a center and the same radius, draw an arc larger than the given angle that intersects ray BC at F

Set the compass to the distance DE.

Using F as a center make a 2nd arc that intersects the 1st arc at a point G

Draw a ray from B through G

The angle GBF is congruent to the angle A

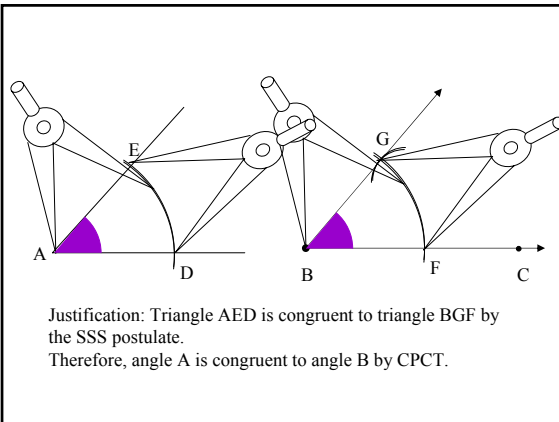

Justification: Triangle AED is congruent to triangle BGF by the SSS postulate. Therefore, angle A is congruent to angle B by CPCT.

Construction 3

Given: $\angle A$

Construct: The bisector of the angle.

Steps for the construction:

Using (A) as a center draw an arc that intersects both sides of the angle at points B & C

Using both B & C as centers and the same radius, draw intersecting arcs inside the angle. Label the intersection of the arcs D

The ray from (A) through (D) is the bisector of the angle

When practicing this construction, check your result with a protractor.

Justification:

$\triangle ACD \cong \triangle ABD$ by SSS \cong .
 $\angle CAD \cong \angle BAD$ by CPCT.

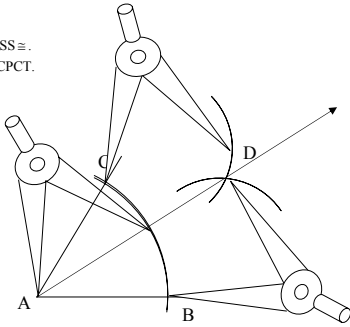

Sample Problem \rightarrow Construct a 60° angle

- Possible Approaches:
 - Guess
 - Create consecutive angle bisectors
 - $180^\circ \rightarrow 90^\circ \rightarrow 45^\circ$
 - Use multiple equal segments of a line
 - Create an equilateral triangle

Sample Problem \rightarrow Construct a 60° angle

1. Draw a line segment AB and label the endpoints.
2. Set the compass to a length less than the length of line segment AB.
3. Using (A) as the center, draw an arc that intersects the line segment and extends well above the line segment.
4. Label the point of intersection of the arc and the line segment C.
5. Without changing the compass setting and using C as the center, draw an arc that intersects the previous arc.
6. Label the point of intersection of the two arcs as point D.
7. Draw the ray AD.
8. Angle DAC is a 60° angle.
9. Check with your protractor.
10. Note that triangle DAC is an equilateral triangle.

Sample Problems

List, in the correct order, the construction(s) necessary to create the diagram described.

Given two segments with lengths a and b , create a new segment with length:

1. $a + b$
3. $3a - b$

5. an equilateral triangle
7. using the SSS method copy a $\triangle ACU$
9. using the SAS method copy a $\triangle ACU$

Sample Problems

Given two angles with measures x and y , create a new angle with measure:

11. $x + y$
 13. $(\frac{3}{4})(x)$

 15. Draw any acute triangle and bisect the angles. Draw any obtuse triangle and bisect the angles. What do you notice about the points of intersection for the bisectors of each type of triangle?
- Construct an angle with measure
17. 120
 19. 165

Sample Problems

21. Draw any $\triangle ABC$. Construct $\triangle DEF$ so that $\triangle ABC \sim \triangle DEF$ and $DE = 2AB$.

23. Given two segments with lengths s and d and an angle with measure n . Create an isosceles triangle with a vertex angle of n and legs of length d .

Section 10-2

Perpendiculars and Parallels

Homework Pages 383-384:

2-24 evens

Excluding 10, 12, 16, 22

Remember to list all construction steps in order and perform the construction.

Objectives

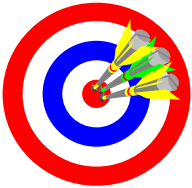

- A. Understand and apply the construction of a perpendicular bisector of a segment.
- B. Understand and apply the construction of a line perpendicular to a given line through a given point on the given line.

- C. Understand and apply the construction of a line perpendicular to a given line and through a point NOT on the given line.
- D. Understand and apply the construction of a line parallel to a given line and through a given point not on the given line.

Reminders, in theory

Postulate 6 → Through any two points there is exactly one line.

Theorem 4-6 → If a point is equidistant from the endpoints of a segment, then the point lies on the perpendicular bisector of the segment.

Postulate 11 → If two lines are cut by a transversal and corresponding angles are congruent, then the lines are parallel.

Construction 4

Given: Segment AB

Construct: The perpendicular bisector of the segment AB

Steps for the construction.

Set the compass to a radius larger than half the segment AB.

Using the A & B as centers, draw two arcs that intersect above and below the given segment. Label the points of intersection C & D

The line CD is the perpendicular bisector of the segment AB.

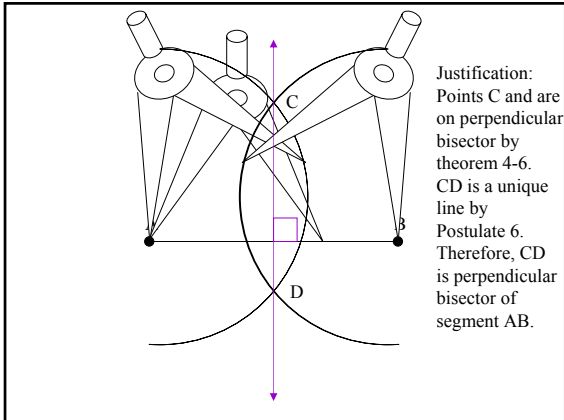

Construction 5

Given: Point (A) on a line AB

Construct: Line AF perpendicular to line AB at the point (A).

Steps for the construction:

Using the point (A) as a center and any radius, draw arcs intersecting the line AB. Label the points of intersection D & E.

Increase the radius. Using D & E as centers, draw intersecting arcs above line AB. Label the intersection point F

The line through AF is perpendicular to line AB at the point (A).

Justification → Points A and F are equidistant from points D and E. Therefore, A and F are on the perpendicular bisector of segment DE. Therefore, line AF is perpendicular to segment DE.

Construction 6

Given: Point (A) outside a line BC

Construct: Line AD perpendicular to line BC from point (A).

Steps for the construction:

- Open the compass wider than the distance from the point (A) to the line BC.
- Using the point (A) as a center, draw an arc that intersect the line BC at two points E & F
- Using E & F as centers draw intersecting arcs to make a point (D) on the opposite side of line BC.
- The line AD is perpendicular to the line BC

Justification → Points A and D are equidistant from points E and F. A and D are on perpendicular bisector, therefore line AD is perpendicular to segment EF.

Construction 7

Given: Point (A) outside a line BC

Construct: Line AD parallel to line BC passing through the point (A)

Steps for the construction:

Draw the line AB

Using construction 2, copy the angle ABC you have just formed so that point (A) is the vertex of the copy.

The side AD of the copied angle is your parallel line.

Justification:

Angle PAD and angle ABC are alternate exterior angles.

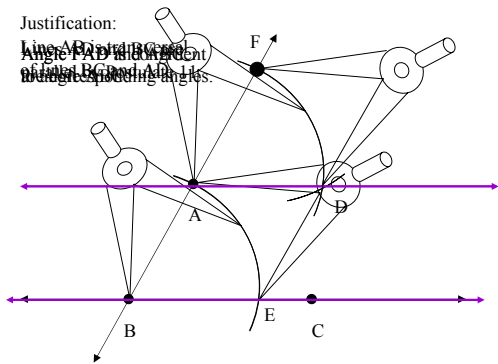

Sample Problem

Construct a 45° - 45° - 90° triangle using point A as vertex and a segment of line BC as one of the sides.

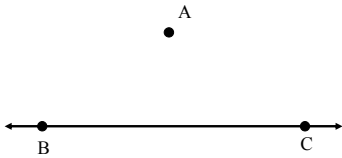

Characteristics of 45° - 45° - 90° triangle:

1. One right angle.
2. Two congruent sides.

Sample Problem

Construct a 45° - 45° - 90° triangle using point A as vertex and a segment of line BC as one of the sides.

Construct line perpendicular to BC through A.

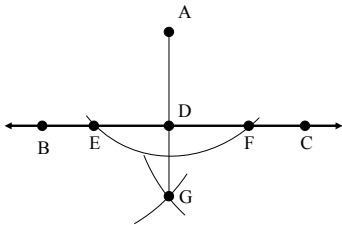

Sample Problem

Construct a 45° - 45° - 90° triangle using point A as vertex and a segment of line BC as one of the sides.

Use D as a center and AD as radius. Draw arc intersecting BC.

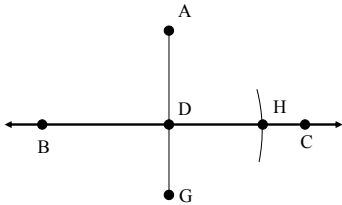

Sample Problem

Construct a 45° - 45° - 90° triangle using point A as vertex and a segment of line BC as one of the sides.

Draw segment AH.

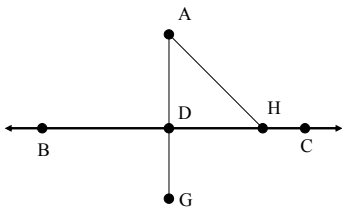

Triangle ADH is a 45° - 45° - 90° triangle.

Sample Problems

1. The perpendicular to l at P .



3. The perpendicular bisector of JK .

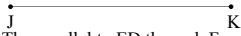

5. The parallel to ED through F .

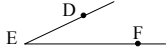

7. The perpendicular to HJ from G .

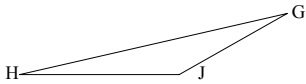

Sample Problems

Construct an angle with the indicated measure.

9. 45°

11. $22\frac{1}{2}^\circ$

13. Draw a segment AB . Construct a segment XY whose length equals $\frac{3}{4}AB$.

15. Draw an acute triangle and construct its three altitudes. Do the lines containing the altitudes intersect in one point? Draw an obtuse triangle and its three altitudes. Answer the same question.

Sample Problems

Given two segments with lengths a and b and an angle with measure n . Construct:

17. A parallelogram with an n angle and sides of length a and b .

19. A square with perimeter $2a$.

21. A square with diagonal of length b .

23. A square with diagonals of length $b\sqrt{2}$.

Section 10-3

Concurrent Lines
Homework Pages 388-389:
2-16 evens
Excluding 6, 8

Objectives

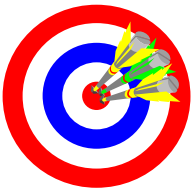

- A. Understand and apply the terms centroid, circumcenter, concurrent lines, incenter, and orthocenter.
- B. Understand and apply the theorems related to the incenter, circumcenter, orthocenter, and centroid of triangles.

★ Concurrent Lines

Concurrent lines → Two or more coplanar lines that intersect at the same point.

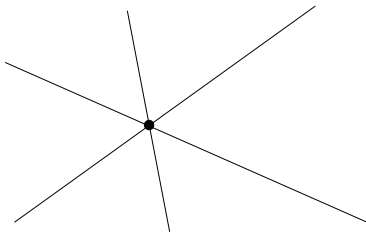

★ Incenter

★ Incenter → The point where the angle bisectors of a triangle intersect.

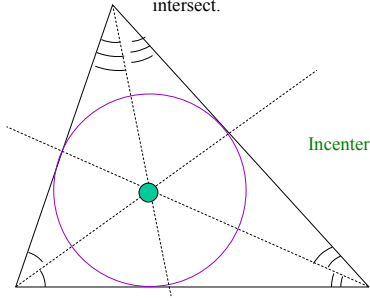

★ Circumcenter → The point where the perpendicular bisectors of the sides of a triangle intersect.

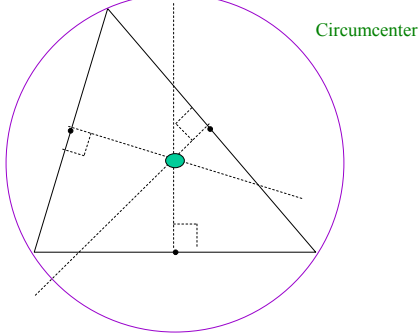

★ Orthocenter → The point where the altitudes of the three sides of a triangle intersect.

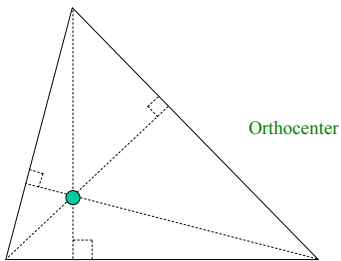

★ Centroid

★ Centroid → the point where the medians of a triangle intersect.

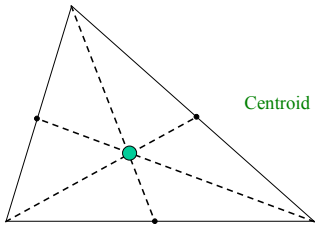

★ Theorem 10-1

The bisectors of the angles of a triangle intersect in a point (incenter) that is equidistant from the three sides of the triangle.

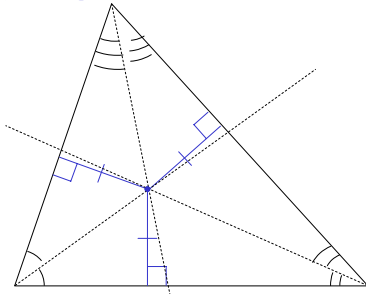

★ Theorem 10-2

The perpendicular bisectors of the sides of a triangle intersect in a point (circumcenter) that is equidistant from the three vertices of the triangle.

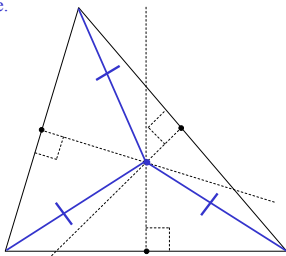

★ Theorem 10-3

The lines that contain the altitudes of a triangle intersect in a point (orthocenter).

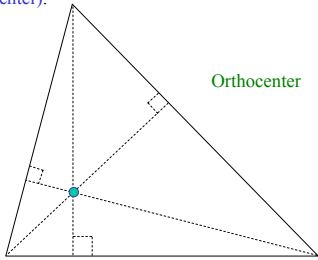

★ Theorem 10-4

The medians of a triangle intersect in a point (centroid) that is two-thirds of the distance from each vertex to the midpoint of the opposite side.

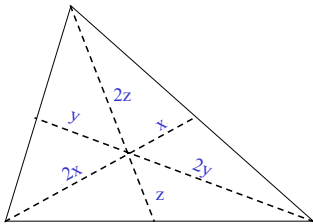

Summary

| <i>Line Type:</i> | <i>Intersect At:</i> | <i>Also:</i> | <i>Distance</i> |
|-------------------------|----------------------|--------------------------------|--|
| Angle Bisectors | Incenter | Center of inscribed circle | Equidistant from sides |
| Perpendicular Bisectors | Circumcenter | Center of circumscribed circle | Equidistant from vertices |
| Altitudes | Orthocenter | | |
| Medians | Centroid | | Point is 2/3 from vertex and 1/3 from side |

Sample Problems

1. Draw a triangle so that the orthocenter is:
 a. inside the triangle b. outside the triangle c. on the triangle

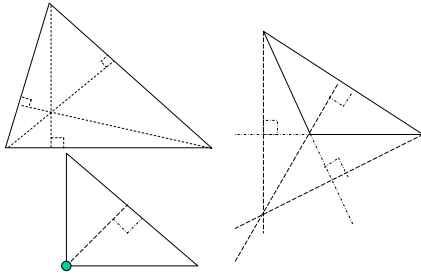

Sample Problems

3. If $AB = 6$, then $BP = ?$ and $AP = ?$
 5. If $PB = 1.9$, then $AP = ?$ and $AB = ?$
 7. Draw a regular pentagon and its angle bisectors.
 9. Three towns, located as shown, plan to build one recreation center to serve all three towns. They decide that the fair thing to do is to build the center equidistant to all three towns. How wise is this decision?

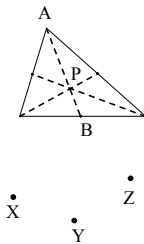

Sample Problems

11. In the figure, AD and BE are congruent medians of $\triangle ABC$.
 a. Explain why $GD = GE$
 b. $GA = ?$
 c. Name three angles congruent to $\angle GAB$

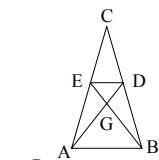

AU , BV and CW are the medians of the triangle

13. If $BP = y^2 + 1$ and $PV = y + 2$, then $y = ?$ or $y = ?$

15. $ABCD$ is a parallelogram with M the midpoint of CD . If BM intersects AC at X , prove that CX is one-third AC .

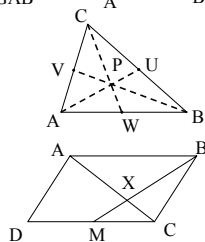

Section 10-4

Circles

Homework Page 395:

2-16 evens

Excluding 8

Remember to list all construction steps in order and perform the construction.

Objectives

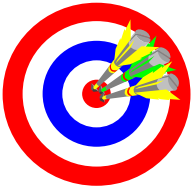

- A. Understand and apply four constructions involving circles.
- B. Identify the justifications for each of the constructions.

Construction 8

Start with a point (A) on a circle O.

Draw the tangent line AB to the circle at the point (A)

Steps for the construction:

Draw the ray OA

Using construction 5, draw the line AB perpendicular to the ray OA at the point (A).

This line AB is the line tangent to the circle at point (A)

Justification → Theorem 9-2: If a line in the plane of a circle is perpendicular to a radius at its outer endpoint, then the line is tangent to the circle.

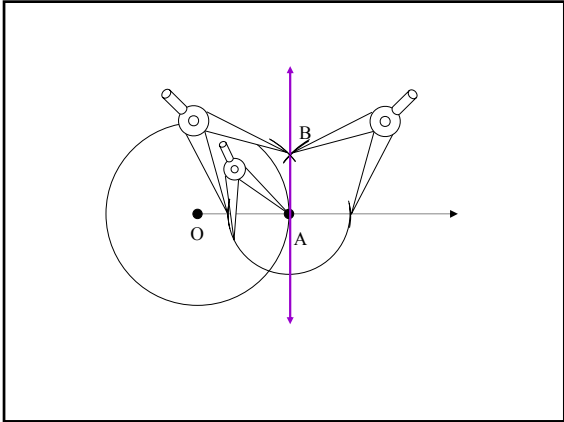

Construction 9

Start with a point (A) outside a circle O

Draw a tangent AD to the circle from the point (A)

Steps for the construction:

Draw the segment OA.

Using construction 4, find the midpoint (B) of this segment.

Set the radius of the compass to AB draw a circle B

The two points D & E where circle B intersects circle O are the points of tangency

AE & AD are tangents to circle O from point (A)

Justification:

1. ~~By the construction, the line segment AB is perpendicular to the line segment DE, and the line segment AD is perpendicular to the line segment DE, therefore, triangle OAD must be a right triangle.~~

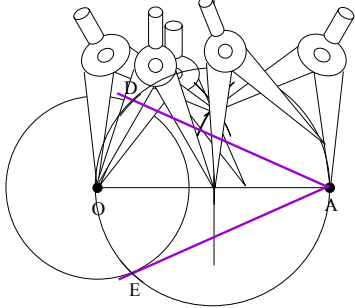

Constructions 10

Start with a triangle ABC

Draw a circumscribed circle O around the triangle ABC.

Steps for the construction:

Using construction 4, draw the perpendicular bisectors for two of the sides of the triangle

The intersection (O) of the perpendicular bisectors is the center of your circle.

Set the radius to the distance between O & A and draw the circumscribed circle O.

Justification → Theorem 10-2: The perpendicular bisectors of the sides of a triangle intersect in a point that is equidistant from the three vertices of the triangle. (Circumcenter)

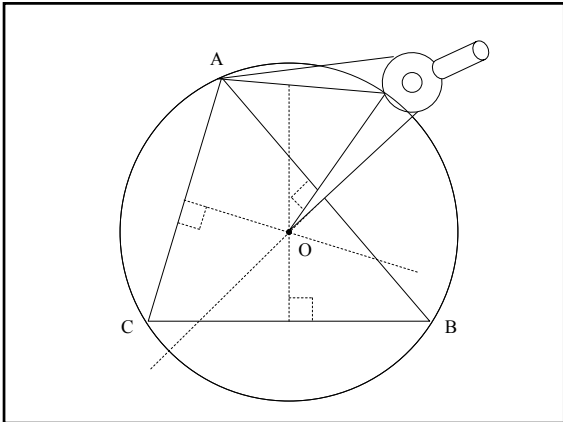

Construction 11

Start with a triangle ABC

Draw an inscribed circle O inside.

Steps for the construction:

Using construction 3, draw the angle bisectors for two of the triangle's angles.

The intersection (O) of the bisectors is the center of the circle.

Using construction 6 draw a line from (O) perpendicular to side of the triangle; this segment will be your radius.

Set your radius to the length of this segment and draw the circle O

Justification → Theorem 10-1: The bisectors of the angles of a triangle intersect in a point that is equidistant from the three sides of the triangle. (Incenter)

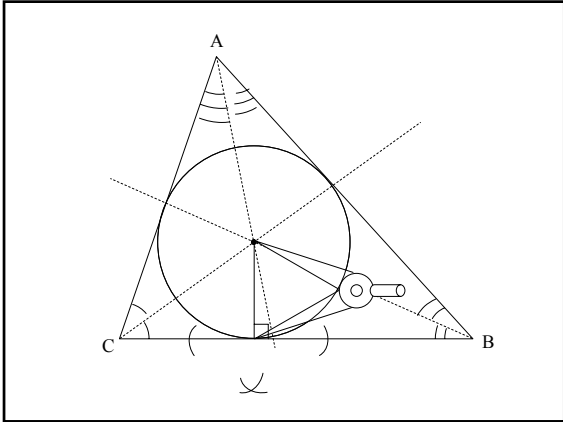

Sample Problems

1. Given a point A on $\odot O$ and a point P not on the circle, construct a tangent at A.

Sample Problems

3. Draw a large acute triangle, construct the circumscribed circle.
5. Draw a large obtuse triangle, construct the circumscribed circle.
7. Construct a large right triangle. Construct the inscribed circle.
9. Draw a circle. Inscribe an equilateral triangle.
11. Draw a circle. Inscribe a regular octagon.
13. Construct a square. Circumscribe a circle.
15. Draw a circle. Circumscribe an equilateral triangle.
17. Given a $\odot O$ and a line l . construct a line that is perpendicular to l and tangent to the circle.

Section 10-5

Special Segments

Homework Page 399:

2-14 evens

Excluding 12

Remember to list all construction steps in order and perform the construction.

Objectives

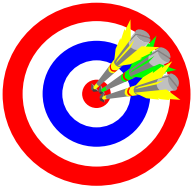

- A. Understand and apply the construction that allows you to divide a segment into a set number of congruent segments.
- B. Understand and apply the construction that allows you to construct proportional segments.

- C. Understand and apply the construction of the geometric mean of two segments.
- D. Identify the justifications for each construction.

Construction 12

Start with a segment AB

Divide the segment into congruent parts.

Choose a point (C) not on segment AB and draw segment AC.

Using any radius, mark off the necessary number of congruent segments on the line you have just drawn.

Connect the last of the points on the line to the other endpoint of the given segment.

Using construction 2, copy the angle formed by the two lines you have drawn to the points you created on the first line; thereby creating a number of parallel lines.

Where these parallel lines cross the given segment are the endpoints of its congruent parts.

$AX=XY=YZ=ZB$

Justification \rightarrow Theorem 5-9: If 3 \parallel lines cut off congruent segments on one transversal, then they cut off congruent segments on every transversal.

Construction 13

Start with three segments with lengths a , b & c

Draw a fourth segment with length d so that the four segments make the proportion $a : b = c : d$.

Draw an angle.

On one side copy the two segments a & b .

On the other side copy the remaining segment c .

Connect the endpoint of a to the endpoint of c .

Using construction 2, copy the angle formed by the line you have just drawn to the endpoint of the second segment; thereby creating a line parallel to the line you drew.

Where this parallel line crosses the other side of the angle you started with is the endpoint of your proportion segment.

$\frac{a}{b} = \frac{c}{d}$

Justification \rightarrow Theorem 7-3: If a line parallel to one side of a triangle intersects the other two sides, then it divides those two sides proportionally.

NOTE! Segments 'a' and 'b' must be on the same ray/segment.
Segments 'c' and 'd' must be on the same ray/segment. 'a' and 'c' must be *across* from each other.

Construction 14

Start with two segments a & b

Draw a third segment c that is their geometric mean.

Draw a line and copy a & b onto the line so that they share an endpoint.

Using construction 4, locate the middle of their sum and draw a circle so that the sum of the segments is a diameter.

Using construction 5, draw a line perpendicular to the sum at their common endpoint.

Where the perpendicular crosses the circle is the end of the segment which is the geometric mean of the two given.

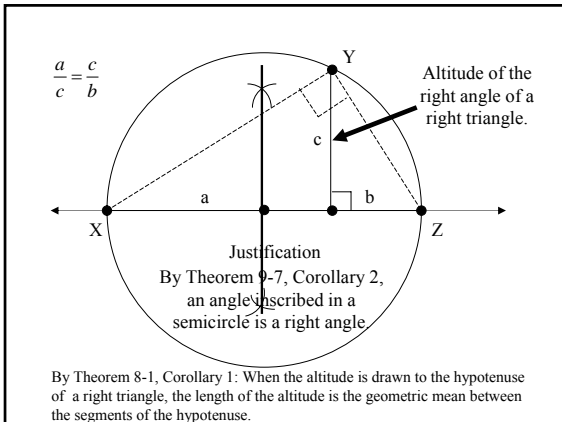

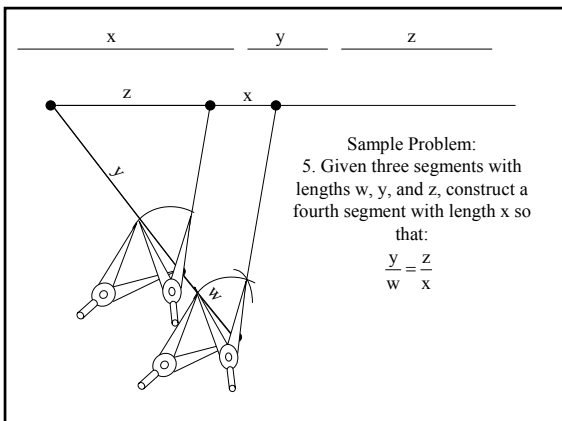

Sample Problems

11. Given two segments with lengths y and p , construct a third segment with length x so that: $x = \frac{1}{3}\sqrt{yp}$

Change the form of the equation using some basic mathematics:

$$x = \frac{1}{3}\sqrt{yp}$$

Set $m = 3x$ so that: $\frac{m}{y} = \frac{p}{m}$

$$3x = \sqrt{yp}$$

Use construction 14 to construct m .

$$(3x)^2 = yp$$

Use construction 12 to construct $x = \frac{1}{3}m$

$$(3x)(3x) = yp$$

$$\frac{3x}{y} = \frac{p}{3x}$$

Sample Problems

- Given a line segment AB . Divide AB into three congruent parts.
- Divide AB into five congruent parts. Can you use construction 4 to divide AB into five congruent parts? Divide AB into segments that have a 2:3 ratio.

Given four segments with lengths w , y , z and p , construct a fourth segment with length x so that:

7. $x = \sqrt{yp}$

9. $zx = wy$

13. $x = \sqrt{6yz}$

Section 10-6

The Meaning of Locus
Homework Pages 404-405:

2-18 evens

For problems 14 and 16, DRAW and describe the locus of points.

Objectives



- A. Understand and apply the term 'locus' or 'locus of points'.
- B. Identify the locus of points related to two- and three-dimensional figures.

★ locus: the set of all points and only those points that satisfy one or more conditions

Sample Problems

Exercises 1-4 deal with figures in a PLANE. Draw a diagram and provide a description of the locus.

1. Given two points A and B, what is the locus of points equidistant from A and B?

Conditions to satisfy:

- A. All locus points must be equidistant from A and B.
- B. All locus points must be in the same plane.

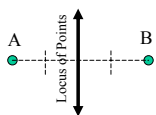

Description of locus of points:
All points on the perpendicular bisector of segment AB.

Sample Problems

Given a square ABCD, draw and describe the coplanar points on or inside the square that satisfy the given condition.

7. Equidistant from AB and BC.

Conditions to satisfy:

- A. All locus points must be equidistant from AB and BC.
- B. All locus points must be in the same plane.
- C. All locus points must inside or on the square.

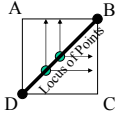

Description of locus of points:
All points on the segment (diagonal) BD.

Sample Problems

Describe the locus in space. (Note: do not draw)

11. Given point E, what is the locus of points 3 cm from E?

Conditions to satisfy:

- A. All locus points must be 3 cm (equidistant) from point E.
- B. Locus points exist *anywhere* in space (3-dimensional).

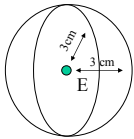

Description of locus of points:
All points on a sphere with center E and radius of 3 cm.

Sample Problems

Write a description of the locus.

3. Given a line h, what is the locus of points 2 cm from h?

Given a square ABCD, name the points inside the square that satisfy the given condition.

5. Equidistant from AB and CD.

Describe the locus in space.

9. Given two parallel planes, what is the locus of points equidistant from the two planes?

Sample Problems

Describe the locus in the plane.

13. Describe the locus of points equidistant from the sides of an angle.

15. Given a segment AB, describe the locus of a point P such that $\angle APB$ is a right angle.

17. Given the segment EF, describe the locus of point G such that $\triangle EFG$ is isosceles with leg EF.

Describe the locus in space.

19. Given a square, what is the locus of points equidistant from the sides?

Section 10-7

Locus Problems

Homework Pages 407-409:

2-18 evens

Excluding 14

Objectives

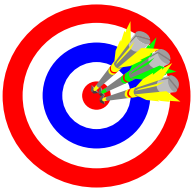

- A. Understand and apply the concept of a multi-conditional locus.
- B. Properly diagram and describe multi-conditional locus.

Locus Focus

Remember, a locus is the **figure** represented by the set of all points, and only those points, that satisfy a set of conditions.

However, it is possible to diagram and describe multiple locus, or loci.

Problems involving loci generally deal with the intersection of multiple, individual locus.

Some problems will have more than one possible locus, in which case all possibilities must be described.

★ Problems with Multiple Condition

- Finding the locus of a problem with more than one condition
 - Draw a diagram which represents the initial given information.
 - Identify the locus of each condition
 - The set of points representing the intersection of the locus for all of the conditions is the locus of the problem.

Sample Problems

Draw and describe the locus in a plane.

1. Draw a $\odot O$ and two points A and B such that the locus of points on $\odot O$ and equidistant from both A and B is:

a. 2 points

Draw the first locus \rightarrow locus of points on $\odot O$.

Draw the second locus \rightarrow equidistant from both A and B.

Draw the diagram to satisfy the locus requirements.

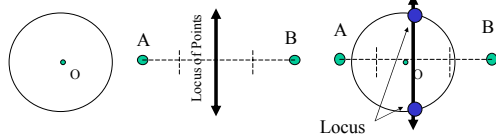

Sample Problems

Draw and describe the locus in a plane.

1. Draw a $\odot O$ and two points A and B such that the locus of points on $\odot O$ and equidistant from both A and B is:
 - b. 0 points

Draw the diagram to satisfy the locus requirements.

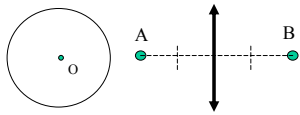

Sample Problems

Draw and describe the locus in a plane.

1. Draw a $\odot O$ and two points A and B such that the locus of points on $\odot O$ and equidistant from both A and B is:
 - c. 1 point

Draw the diagram to satisfy the locus requirements.

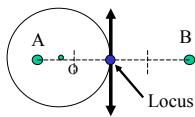

Sample Problems

Draw and describe the locus in a plane.

7. Points A and B are 3 cm apart. What is the locus of points 2 cm from both A and B?

Conditions to satisfy:

1. Locus points are coplanar to points A and B.
2. Points A and B are 3 cm apart.
3. Locus points are 2 cm from both A and B.

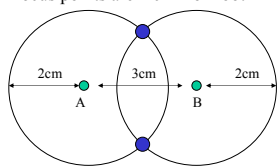

Locus Points
 Description of Locus:
 The 2 points of intersection of circles with radius of 2 centimeters and centers of A and B.

Sample Problems

13. Given a point A and two parallel lines j and k, what is the locus of points 30 cm from A and equidistant from j and k?

0 Points? 1 Point? 2 Points? 4 Points?

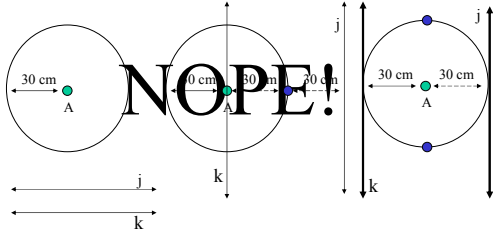

Sample Problems

Draw and describe the locus in a plane.

3. Given two points D and E, what is the locus of points 1 cm from D and 2 cm from E.
5. Point P lies on l. What is the locus of points on l 3 cm from P?
9. Given $\angle A$, what is the locus of points equidistant from the sides of $\angle A$ and 2 cm from the vertex of $\angle A$?
11. Given points C and D, what is the locus of points 2 cm from C and 3 cm from D?

Sample Problems

Describe the locus in space.

15. Given plane Z and point B outside Z, what is the locus of points in Z that are 3 cm from B?
17. Given line $AB \perp$ plane Q, what is the locus of points 2 cm from AB and 2 cm from Q?
19. Given point A in plane Z, what is the locus of points 5 cm from A and d cm from Z?

Sample Problems

21. Points R, S, T and W are not coplanar and no three of them are collinear.
- a. the locus of points equidistant from R and S?
 - b. the locus of points equidistant from R and T?
 - c. the loci from parts a and b intersect in a ? and all points in this ? are equidistant from R, S, and T.
 - d. the locus of points equidistant from R and W?
 - e. the intersection of the figures in c and d is a ?. This ? is equidistant from the four given points.

Section 10-8

Locus and Construction
Homework Pages 412-413:
2-10 evens
Perform as CONSTRUCTIONS.
Do NOT list the steps.
DESCRIBE the solution.

Objectives



- A. Apply the concept of locus in the solution of construction exercises.

Example

- Given angle n° and segments r and s , construct $\triangle ABC$ with:
 - Measure of angle $A = n^\circ$
 - $AB = r$
 - Altitude to segment AB having length s .
- Consider the three bulleted items to be multiple conditions of a locus.
- Remember that a locus may be represented by one or more figures!

Example (continued):

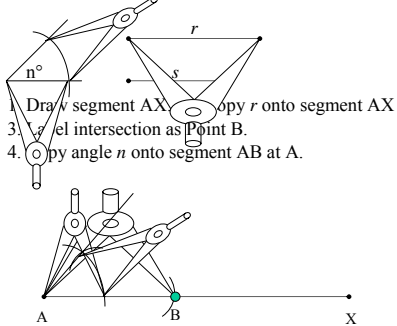

Example (continued):

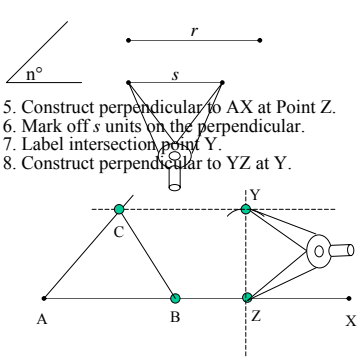

Sample Problems

1. Draw any segment AB and a segment with length h. Construct the locus of points P such that for every $\triangle APB$ the altitude from P to AB would equal h.
3. Draw $\angle XYZ$. Construct a circle with a given radius a , that is tangent to the sides of $\angle XYZ$.
Given an angle with a measure of n and three segments with lengths r , s and t .
5. Construct segment AB with length $= t$. Then construct the locus of all points C so that in $\triangle ABC$ the altitude from C has length r .
7. Construct isosceles triangle $\triangle ABC$ so that $AB = AC = t$ and so that the altitude from A has length s .

Sample Problems

9. Construct $\triangle ABC$ so that $AB = t$, $AC = s$, and the median to AB has length r .
11. Construct $\triangle ABC$ so that $m\angle C = 90$, $m\angle A = n$, and the altitude to AB has length s .
13. Construct $\triangle ABC$ so that $AB = t$, and the median to AB and the altitude to AB have lengths s and r respectively.
15. Construct both an acute and an obtuse isosceles triangle such that each leg has length s and each altitude to a leg has length r .

Chapter 10

Constructions and Loci
Review
Homework Page 418:
2-12 evens
